

AK28 Series Elevator Push Buttons



Button Optional	Feature
<p>1) LED color: red LED,blue LED,yellow LED, other color LED</p> <p>2) Braille: without braille</p> <p>3) Button surface: flat surface</p> <p>4) Connection:wire connection</p> <p>5) Voltage:DV24V,DC12V</p> <p>6) Normal open,normal closed</p> <p>7) Number and figure in buttons surface: 1,2,3...64,DOOR OPEN,DOOR CLOSE, ARROW UP,ARROW DOWN,ALARM,CALL, G,B,P,B1,etc</p>	<p>1) Button surface material:outer frame material is ABS,button surface cover material is stainless steel</p> <p>2) The thickness of installation plate:2-3mm</p> <p>3) Installed by plastic clipping</p> <p>4) Fire-proof components,in accordance with European standard EN-81</p> <p>5) Life: >300000 time of operation life for normal micro-switch inside</p> <p>6) General use type,suitable for all elevator</p>

Circuit Diagram:

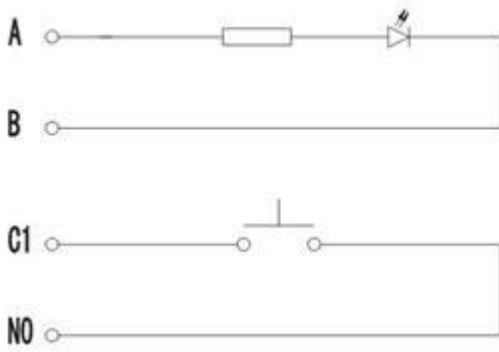
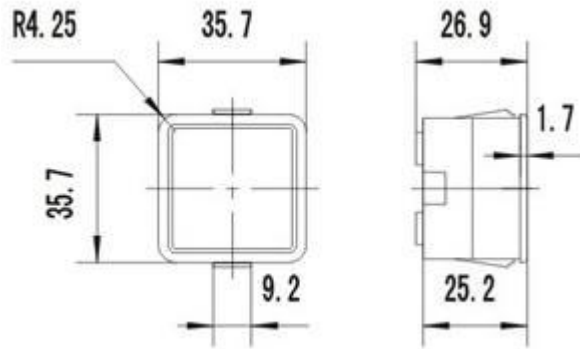

Figure Dimension:



Install Mounting Dimension:

