

AK15B Series Elevator Push Buttons



Button Optional	Feature
1) LED color: red LED,blue LED,white LED,other color LED 2) Braille: without braille in the button surface 3) Button surface: flat surface 4) Connection:wire connection 5) Voltage:DV24V,DC12V 6) Normal open,normal closed 7) Number and figure in buttons surface: 1,2,3...64,DOOR OPEN,DOOR CLOSE,ARROW UP,ARROW DOWN,ALARM,CALL,G,B,P,B1,etc	1) Button surface material:outer frame material is ABS,button surface cover material is transparent PC 2) The thickness of installation plate:2-3mm 3) Installed in panel with welded screw clip 4) Fire-proof components,in accordance with European standard EN-81 5) Life: more then 5 million of operation life 6) Reference supplied for MITSUBISHI elevator

Web:www.elevator-buttons.com

Email:sales@elevator-buttons.com

Circuit Diagram:

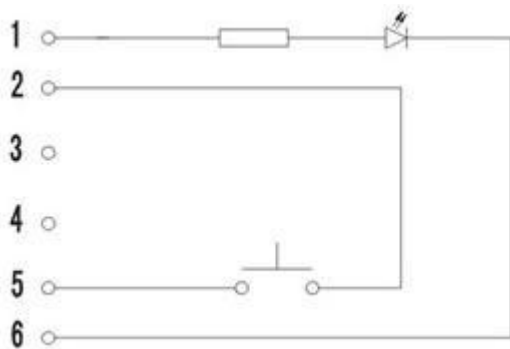
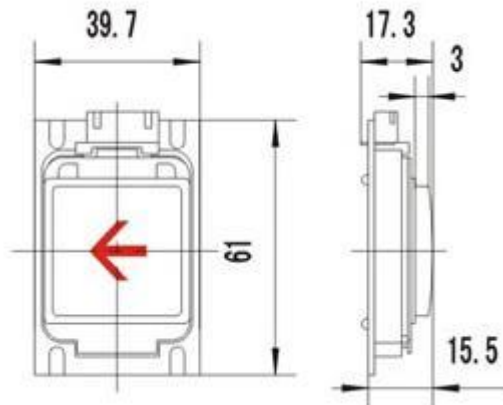

Figure Dimension:



Install Mounting Dimension:

